

DX16 & DX18 | DIRECT DRIVE

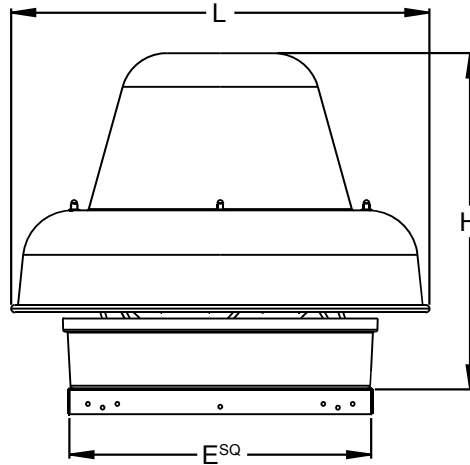

Model	Dimensions			
	L (Dia.)	H	E*	Ro
DX16V/S/R, Q1 & Q2	28 ½	22 ½	20 ½ x 20 ½	16 x 16
DX18V	39	31	28 ½ x 28 ½	20 x 20

All dimensions are in inches. *Outside dimension of curb should be 1 ½" less than "E" dimension.

Model	Nominal			Tip Speed FPM	0.000" SP		0.125" SP		0.250" SP		0.375" SP		0.500" SP		0.625" SP		0.750" SP		0.875" SP		1.000" SP		1.250" SP	
	HP	Max Watts	RPM		CFM	Sones	CFM	Sones	CFM	Sones	CFM	Sones	CFM	Sones	CFM	Sones	CFM	Sones	CFM	Sones	CFM	Sones	CFM	Sones
DX16V	1/6	453	1050	3788	1738	9.9	1489	8	1256	6.6	1032	6.1	884	6.6	772	7.1	682	7.9	598	9.9	529	10.1	392	10.2
DX16S	1/3	510	1300	4690	2021	12	1822	10.6	1637	9.5	1428	8.7	1256	8.4	1094	8.5	943	9.3	850	10.2	775	11	606	12.3
DX16R	1/3 ⁽¹⁾	574	1550	5592	2346	13.8	2176	12.8	2014	12	1853	11.3	1685	10.7	1532	10.4	1384	10.1	1247	10	1115	10.4	881	12.4
DX16Q1	1/2	688	1650	5953	2701	16.9	2576	16.4	2465	15.9	2352	15.5	2228	15	2096	14.4	1966	14	1839	13.6	1700	13.5	1401	13.5
DX16Q2	3/4	866	1725	6223	3016	17.7	2921	17.1	2829	16.7	2747	16.3	2665	15.9	2575	15.5	2484	15	2371	14.6	2256	14.2	2005	13.3
DX18V	3/4	964	1075	6029	4561	21	4395	19.8	4230	19.1	4053	18.5	3865	17.9	3671	16.9	3454	16.4	3237	16.4	2995	16.4	2405	16.4

(1) TE motor is 1/2 Hp.

Performance certified is for installation Type A: Free Inlet, Free Outlet. Speed (RPM) shown is nominal. Performance is based on actual speed of test. The sound ratings shown are for loudness values in fan sones at 5'0" (1.5m) in a hemispherical free field calculated per AMCA International Standard 301. Values shown are for installation Type A: free inlet hemispherical sone levels. Performance ratings do not include the effects of appurtenances.

Domex fans are only one component of a total system. As such, fan performance is directly affected by the system. It is critical that system designers determine the actual system loss to ensure that the actual flow is specified in the system design.